

## ASH CONVEYOR

The Runarsson ash conveyor is designed for transporting wet ash. Ash from the boiler grate falls into the conveyor, which due to high ash temperature is filled with water.

Cooled ash is moved along the bottom of the conveyor to the ash bin or container by means of scrapers attached to the transport chain. Before the ash is moved into a container, excess water is drained in the oblique section of the conveyor during its transport.

### Advantages:

- low energy consumption
- high resistance to corrosion and wear
- low water consumption
- efficient operation

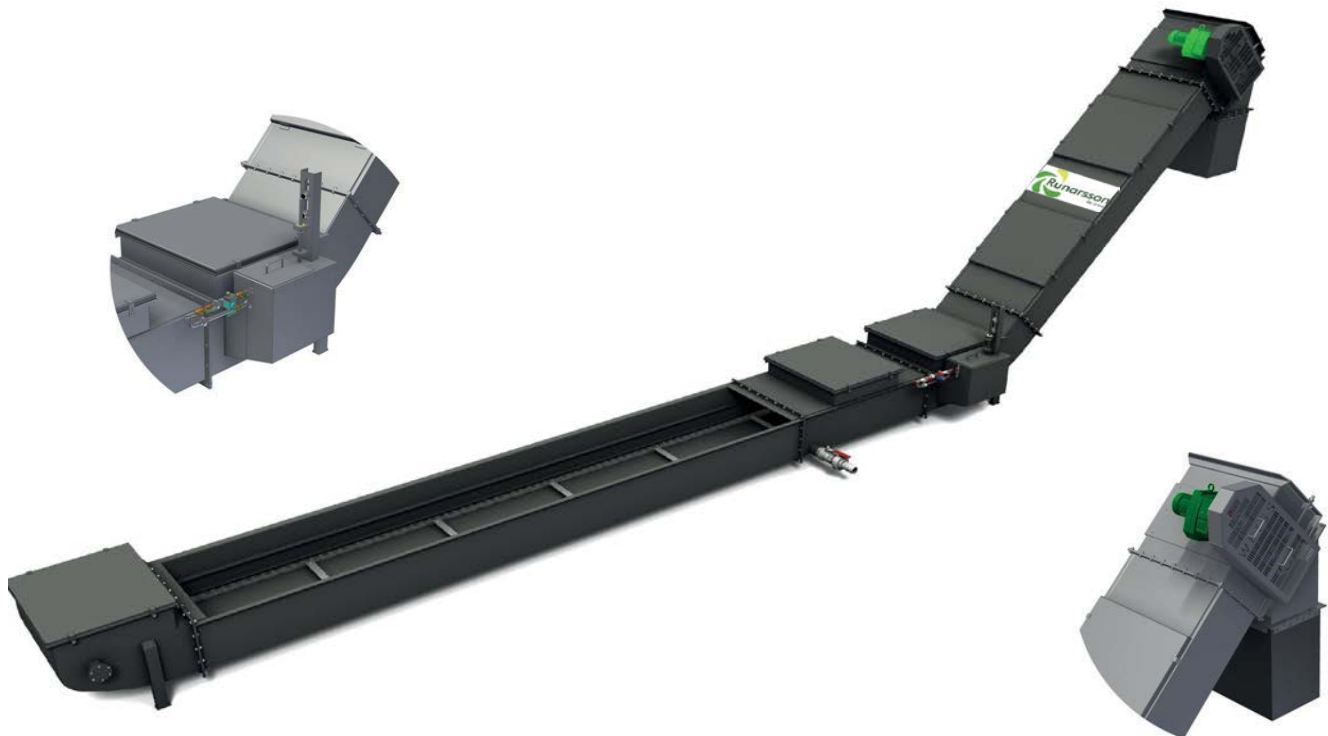

## ASH CONVEYOR



The conveyor is produced in two standard widths: 560mm and 860mm. The length of the ash conveyor can be adjusted depending on customer requirements.

### Technical Data

UNIT		TYPE	
		A-V 560	A-V 860
Capacity	m <sup>3</sup> / h	0.2	0.33
<b>DIMENSIONS</b>			
Width	mm	560	860
Height	mm	adjustable	adjustable
Length	mm	adjustable	adjustable
Power	kW	0.75	0.75
Chain	Mm	100	100
Specific ash weight - max.	Kg / m <sup>3</sup>	500	500
Ash grains- max.	mm	100 x 100 x 100 mm	100 x 100 x 100 mm